

# Aviva Mainframe Edition Release 7.20

Aviva Mainframe Edition is Eicon Technology's desktop to mainframe connectivity solution for Microsoft Windows NT 4.0 and Windows 95. With powerful automation, intelligent connectivity and advanced diagnostic tools hiding the complexity of SNA communications to the user, little or no training or programming is needed to make the most of your mission-critical applications. Aviva is based on a new 32-bit architecture, designed to take full advantage of the new capabilities of Windows 95 and Windows NT 4.0 operating systems.

In today's increasingly complicated technical environment MIS managers need powerful software solutions that require minimum support; LAN administrators want an environment that enables connectivity to different enterprise business applications with low cost of ownership; and end users demand business software that is familiar, inviting and easy to use.

Eicon Technology has addressed these issues and more with the release of Aviva Mainframe Edition, a 3270 display and printer emulation program for users of Windows NT and Windows 95. Aviva comes packed with a widest list of features to make host access easier than ever before for both end users and system administrators.

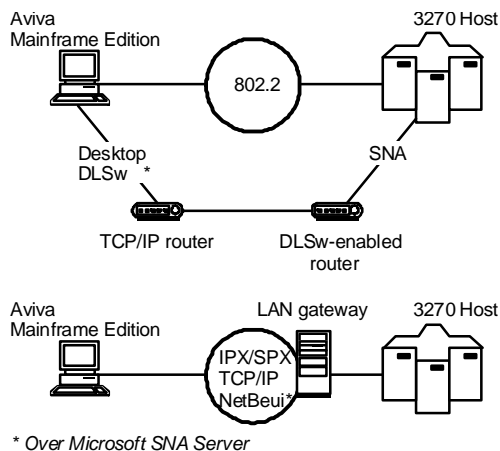

## ■ Product Highlights

- **3270 Display and Printer emulation**
- **Intuitive User Interface - Microsoft Office compatible**
- **Powerful automation - ActiveX Automation and VBA compliant**
- **Intelligent, Dynamic SNA connectivity with trouble shooting aids**
- **System Management and Diagnostic tools**

## What's in it for MIS managers?

Today's MIS managers need to maximize their existing investments in legacy applications. Aviva provides a set of features designed to make their job easier.

Aviva supports Microsoft Systems Management Server (SMS) which allows automated distribution of Aviva across the network. Aviva provides MIS managers with extremely powerful SNA diagnostics features that minimize down time. A comprehensive trace and logging utility, available locally or from a remote site, gives the in-depth analysis needed to streamline problem solving. And, the Property Manager provides an intuitive single point of entry for complete off-line configuration and customization of all Aviva sessions and connection types. Aviva offers corporations a long term connectivity solution that yields reduced training and support costs.

<b>Feature</b>	<b>Benefit</b>
Property Manager <i>Unique</i>	Provides an intuitive single point of entry for complete off-line configuration and customization of all Aviva sessions and connection types
Tracing and Logging Utility	Provides the in-depth analysis needed to streamline problem solving, which can be configured either remotely, or locally within the session
Hot-Backup <i>Unique</i>	Provides automatic reconnection and a dynamic link selection across all connection types, minimizing down time
Session template	Contain the default values that are used by the Session Wizard to create a new display or printer session. These default values can be modified by the system administrator in order to better fit a specific corporate environment
Wizards	Provide step-by-step instructions to create new session and destinations. To simplify the process even more, the Wizards use the default values contained in the session templates
SMS support	Provides scripts that allow attended or unattended installations of Aviva across the network using Microsoft Systems Management Server
Resource Kit <i>Unique</i>	An outline manual designed to provide MIS professional with additional tools and information needed for installing, configuring and supporting Aviva Mainframe Edition

## What's in it for LAN Administrators?

LAN Administrators will be asked to automate and pre-set the end-user access to the host information in order to minimize the impact of the product roll-out. They will also need to automate the integration of host information with popular desktop applications to increase productivity.

Aviva supports ActiveX (OLE 2.0) automation, making it easy to integrate SNA information with Windows NT and Windows 95 applications such as Microsoft Excel. **EiconBasic**, the Aviva advanced macro language, supports the same familiar Visual Basic for Applications interface used by over a million MS Office developers worldwide, to automate desktops.

Aviva lets LAN administrators pre-set end-users' configuration to either help them choose the functions that they need, or to control what functions they have access to.

<b>Feature</b>	<b>Benefit</b>
ActiveX automation  <i>Unique</i>	Aviva functions both as an ActiveX Controller and Server, which means it can control or be controlled by other ActiveX compliant applications such as MS Excel or Visual Basic. This allows users to easily integrate host information with popular desktop applications
WinHLLAPI	Enables third party applications that are written to this API to communicate with Aviva
Macro dialog editor	Lets users automate routine tasks such as logging on to the host and copying information between sessions; macros can be assigned to keyboard mappings, toolbar buttons, menu items, hotspots and screen triggers through the Macro Manager
VBA compatible macro language  <i>Unique</i>	EiconBasic is an advanced macro language that is compatible with Visual Basic for Applications (VBA). EiconBasic supports the familiar VBA syntax promoted by Microsoft in all its MS Office products, so that users familiar to MS Office 95 applications don't have to learn a new macro language
Graphical Toolbar	Aviva can display multiple graphical toolbars that can be customized and positioned anywhere on the screen. Aviva toolbars feature ToolTips that display a descriptive text for each button
Screen Triggers	A Screen Trigger is a pre-defined area of the session window in which Aviva searches for a specified word or phrase generated (sent to the screen) by the host computer and, depending on the word or phrase sent, executes a pre-assigned macro or emulation text string

---

Toolbar and Menu Editors	Lets LAN administrators add, move, remove or rename menus and toolbars, as well as assign menus to macros and emulation text. The process of editing a menu or toolbar is identical to that of standard Microsoft Office products. This feature is useful for system administrators who want to pre-set users' configuration to either help them choose the functions that they need, or to control what functions they have access to
Host color remapping	Lets LAN administrators customize the user interface to maximize screen visibility
Configure Hotspots	Eliminate the need to use keyboard function keys. Can be pre-set by the administrator in the session template
MAPI-compliant messaging	Enables users to send display screens and diagnostic files to LAN administrators via e-mail. Administrators can see the problem first hand, which helps get a user running again as quickly and easily as possible
<i>Unique</i>	
Tooltips on OIA line	The OpView line converts cryptic Operator Information Area (OIA) symbols into plain English (via ToolTips) which provides an intuitive way to streamline connecting problems. Right clicking on the Tooltip provides context sensitive help.
<i>Unique</i>	
OIA merged with status bar	The contents of the OpView can also be presented as text information in the status bar, providing more space to display data
3D View	Lets the LAN administrators put a graphical face on legacy applications without writing a single line of code, and let corporations focus their development efforts where they are needed
<i>Unique</i>	
Drag and Drop file transfer	Provides an intuitive user interface to transfer files between systems. LAN administrators can set up Portfolios of frequently used files to simplify batch file transfers. Aviva also supports the IND\$FILE+ transfer from Proginet, allowing corporations that use this host environment to reduce the time and cost of transferring files
Printer Services for Windows NT	Provides an ideal replacement solution for the "host print" functionality usually found in SNA gateway devices. Aviva Mainframe Edition 7.20 is the only SNA client to provide printer services for Windows NT without any additional charges.
<i>Unique</i>	

---

## What's in it for end-users?

The Eicon Aviva trademark is the ease with which users can access host applications. Aviva builds upon the functionality of Windows 95 with an innovative user interface, so that users will feel at home in their desktop environment and training costs can be reduced.

<b>Feature</b>	<b>Benefit</b>
Microsoft Office compatible 	Means that its toolbars, menus, and accelerator keys are similar to those used by Microsoft Office applications. If users are already familiar with Microsoft Office applications (Excel, Word, Microsoft Access and PowerPoint), then many of the tasks they have learned in Office can be completed in a similar manner in Aviva Mainframe Edition, minimizing training requirements significantly
Run without UI  <i>Unique</i>	The benefits for corporations using graphical front end applications is double. 1. Additional system resources are available. 2. Users are not confused by the Aviva session icon on the taskbar.
Hot-Backup  <i>Unique</i>	Provides automatic reconnection and a dynamic link selection across all connection types minimizing down time
Context-sensitive Help	Provides short, functional descriptions of items, and is displayed in a box that pops-up near the item. A "What's This" help is also included in every dialog box
Tour Guide  <i>Unique</i>	A built-in help agent that provides tours of dialog boxes, minimizes training requirements by familiarizing the user with application elements
Quick Start booklet  <i>Unique</i>	A short and concise manual that help users to install and configure Aviva.

**Eicon Technology Corporation**

Tel.: (514) 745-5500  
 Fax: (514) 745-5588

**In the United States, Canada, Latin America:**

Tel.: 1-800-80-EICON  
 (214) 239-3270  
 Fax: (214) 239-3304

**In Europe, Middle East, Africa:**

Tel.: (44) 181 967-8000  
 Fax: (44) 181 967-8050

**In Australia, New Zealand, Asia:**

Tel.: (61) 2 9919-7200  
 Fax: (61) 2 9929-6300

**Internet:**

North America: sales@eicon.com  
 Europe: sales.europe@eicon.com  
 Asia Pacific: sales.asiapac@eicon.com  
 Worldwide Web: <http://www.eicon.com/>

